

AC CONVERTER / BATTERY CHARGER

User's Manual

Foxpower Technology Limited

Add: Floor 3th, Building 2nd, Selen Tech-park, Tangjia Rd, Fenghuang, Guangming District, Shenzhen, China

Tel: +86-755-23242321

Fax: +86-755-23242321

Cell: +86-13510672617

Whatsapp: +8613510672617

Email: benson@foxpowerups.com

Web: <https://www.foxpowerups.com>

Web: <https://www.fox-power.com>

BRITMAR MARINE

UNIT 102 - 2433 Dollarton Highway

North Vancouver, BC CANADA V7H 0A1

Toll-Free: (866) 401 - 2288

Info@Britmar.com

Contents

INTRODUCTION	3
Important Safety Instructions	3
1. General Description	5
1.1 Features	5
2. Installation and Operation	6
2.1 Front Panel Description	6
2.2 Rear Panel Description	7
2.3 DC Output Battery Connection	8
2.4 AC Input Connection	12
2.5 Parallel Connection	12
3. Troubleshooting	12
4. Specifications	13

INTRODUCTION

This product will bring you reliable power when used and maintained properly. This manual provides safety guidelines, detailed planning and setup information, installation procedures, as well as information about operating and troubleshooting the unit. This manual does not provide details about specific brands of batteries.

READ THE MANUAL AND UNDERSTAND ALL SAFETY PRECAUTIONS BEFORE INSTALLING AND OPERATING THE UNIT. SAVE THE MANUAL FOR FUTURE REFERENCE.



Important Safety Instructions

CAUTION

1. Installation and service should be performed by a qualified service technician. High voltage is present inside unit. Incorrect installation or use may result in risk of electric shock or fire. No user serviceable parts inside the unit.
2. Remove all sources of power, utility and battery power before servicing or installing.
3. Risk of explosive gases
 - ◆ Working near batteries is dangerous. Batteries produce explosive gases during normal battery operation.
 - ◆ To reduce risk of battery explosion, follow the instructions in this manual and the instructions from the battery manufacturer.
4. Plan ahead
 - ◆ Someone should be within range of your voice or close enough to come to your aid when working near a lead-acid battery.
 - ◆ Have plenty of fresh water and soap nearby in case battery acid contacts skin, clothing or eyes.

- ◆ Wear complete eye protection and clothing protection. Avoid touching eyes while working near battery.
- ◆ If battery acid contacts skin or clothing, wash immediately with soap and water. If acid enters eye, immediately flood eye with running cold water for at least 10 minutes and get medical attention immediately.
- ◆ NEVER smoke or allow a spark or flame in vicinity of battery.
- ◆ Be extra cautious to reduce risk of dropping metal tool onto battery. It might spark or short circuit battery or other electrical part that may cause explosion.
- ◆ Remove personal metal items such as rings, bracelets, necklaces, and watches when working with a lead-acid battery. A lead-acid battery can produce a short circuit current high enough to weld a ring or like metal, causing a severe burn.

5. Preparing to charge

- ◆ Never charge a frozen battery.
- ◆ Be sure battery is mounted in a well-ventilated compartment.
- ◆ Add distilled water in each cell until battery acid reaches level specified by battery manufacturer. This helps purge excessive gas from the cells. Do not overfill. For a battery without cell caps, carefully follow manufacturers charging instructions. (only for flooded batteries)

6. Charger location & installation

- ◆ In an event of failure, the unit could produce arcs or sparks. NEVER install in battery or engine compartment or in the presence of explosive gases. Keep all gases away from unit.
- ◆ Protect all wiring from physical damage, vibration and excessive heat.
- ◆ Insure that the unit is properly setup for the type of battery being charged.
- ◆ Do not expose unit to rain or snow.
- ◆ Insure all terminating connections are clean and tight to prevent arcing and overheating.
- ◆ Unit must be properly installed as described in these instructions prior to operation.
- ◆ Do not adjust any functions including the current, voltage and battery type when unit is working. All adjustments must be made when converter is disconnected.

1. General Description

The AC Converter / Battery Charger is ideal for applications that require diverse ways of recharging batteries. There are many ways to recharge batteries and the wide AC input range of this unit accommodates most applications and battery technologies. Useful with generators and shore power and charges various types of batteries: NMC, LiFePO₄, AGM & Gel and open lead acid. This converter is designed with reliable high frequency structure, accepting a wide range input voltage to accommodate unstable inputs. The AC Converter / Battery Charger provides the flexibility for almost any application and the large charging capacity gets the job done quickly.

1.1 Features

- ◆ Three stage variable charging voltage algorithm for maximizing the battery lifetime. Bulk, absorb and float.
- ◆ Large charging capacity design less charging time needed.
- ◆ Adjustable charge current control setting is based on connected battery's capacity to safely charge batteries and avoid over charging.
- ◆ Wide input voltage range.
- ◆ High AC to DC converting efficiency design (higher than 80%).
- ◆ Smart fan control for maximizing the performance and fan life.

2. Installation and Operation

2.1 Front Panel Description



Figure 1 Front Panel

RS232 communication port

BTS Port (Optional BTS)

Connect the BTS to this port.

A battery temperature sensor (BTS) can be used to ensure proper charging of the batteries based on temperature. Installing a BTS extends battery life by preventing overcharging in warm temperatures and undercharging in cold temperatures.

Ground Terminal

Connect the GND to the Ground Terminal using 12 AWG wire.

Battery Connector

Connect the Battery to the Positive(+) Battery Terminal and the Negative(-) Battery Terminal. Do NOT reverse the polarity!

2.2 Rear Panel Description

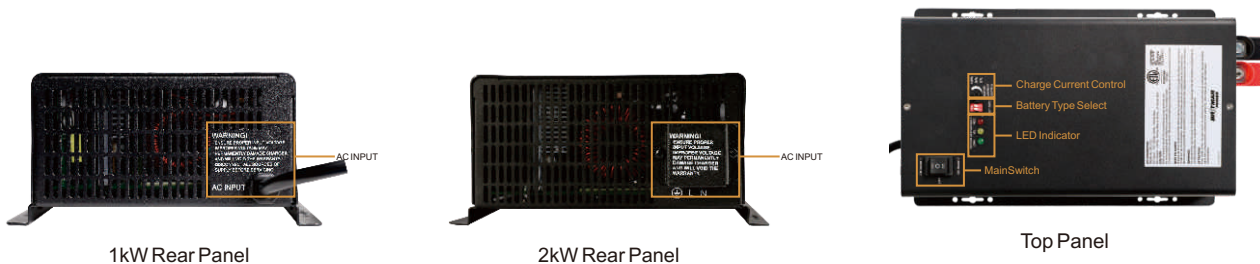

Figure 2

Main Switch

ON Model1: Once the unit has been properly installed and batteries are connected, flip the switch to "ON Model1", the unit will turn on automatically, and works according to the 12Vdc battery bank system.

OFF: Flip the switch to "OFF", the unit will turn off.

ON Model2: Once the unit has been properly installed and batteries are connected, flip the switch to "ON Model2", the unit will turn on automatically, and works according to the 24Vdc battery bank system.

LED Indicator

The unit has green, yellow and red LEDs to indicate the operating status of the AC converter.

Table able 1 — 1: LED status indicator

Conditions	Red(Fault RED)	Yellow(Status YEL)	Green(Status GRN)
Mode select fault	Blinking 0.5s	Blinking 0.5s	Blinking 0.5s
Output voltage too low	Solid	Blinking 2s	Off
Fan fault	Blinking 0.5s	Off	Off
Over temperature	Blinking 2s	Off	Off
Output over voltage	Solid	Blinking 0.5s	Off
Output over current	Solid	Solid	Off
Input over / Under voltage /Frequency	Solid	Off	Off
Constant current / Constant Voltage	Off	Solid	Solid
Float stage	Off	Blinking 2s	Solid
Battery over temperature	Off	Blinking 2s	Off

Battery Type Select

The AC Converter can charge four types of batteries, which can be set using the two battery type select switches.

Table able 1 – 2: Battery Type

Battery Type	SW1	SW2	Bulk Values (12Vdc)	Float Values (12Vdc)	Bulk Values (24Vdc)	Float Values (24Vdc)
NMC	0	1	12.2	12.0	24.4	24.0
LiFePO4	1	0	13.8	13.6	27.6	27.2
Gel&AGM	1	1	14.2	13.6	28.4	27.2
Open Lead acid	0	0	14.4	13.8	28.8	27.6

Charge Current Control Dial

This dial can adjust the amount of charge current. The adjustment range is 20%-100% of the total current rating.

Input terminal

The unit can accept input voltages ranging from 70Vac – 145Vac for BC112/212L .



CAUTION Before connecting, power off the unit and make sure the AC cord is not plugged into an AC outlet.

2.3 DC Output Battery Connection –Battery should be connected first then AC power can be applied.

Step 1- Follow battery polarity guide located near battery terminal! Place the battery cable ring terminal over AC Converter / Battery Charger’s battery terminal. Tighten the M6*12 Screw. Do not place anything between the flat part of battery terminal and the battery cable ring terminal, or overheating may occur.

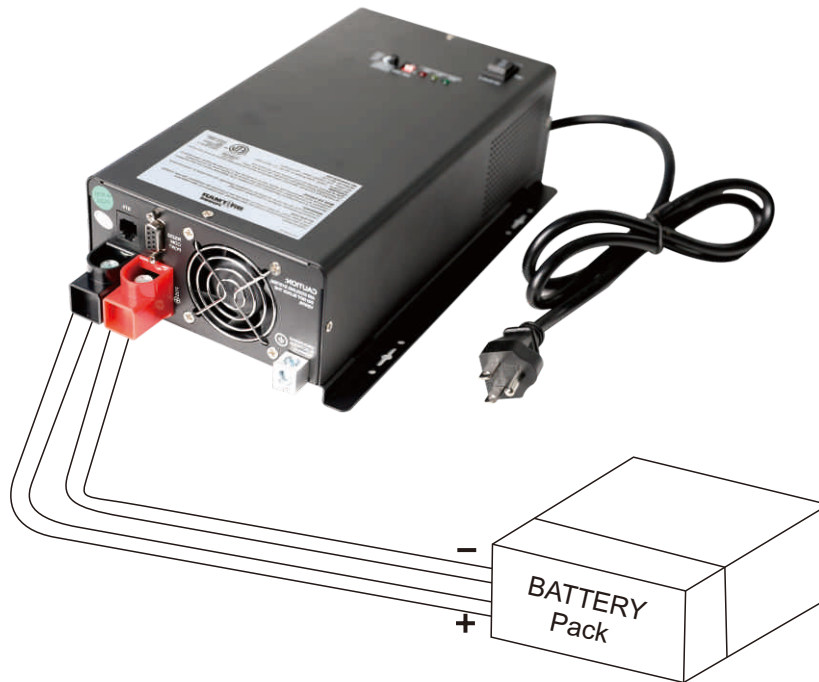
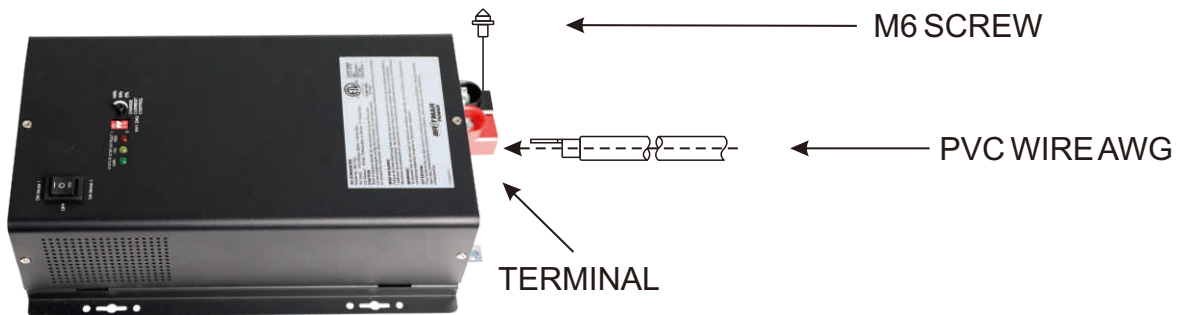

Caution! DO NOT place anything between battery cable ring terminals and battery terminals. The terminal stud is not designed to carry current. Apply anti-oxidant paste to terminals after terminals have been torqued.

Battery Cabling and Hook-up Configurations

Several smaller batteries can be connected to create a battery bank of substantial size. You can connect batteries in three ways: in parallel, series, or series-parallel. To make a larger battery bank, connect individual batteries with heavy cables. The actual size of the cable depends on whether the batteries are connected in parallel or series. Generally, the cable should not be smaller than the inverter cables—if the main cables are 4/0 AWG, the battery interconnects should be 4/0 AWG. The best configuration is to connect the batteries in series and parallel. This requires additional cables, but reduces imbalances in the battery bank and can improve the overall performance. Consult your battery supplier for more information regarding the hook-up configuration required for your system.

Battery Parallel Connection

Batteries are connected in parallel when all the positive terminals of a group of batteries are connected and then, separately, all the negative terminals are connected. In a parallel configuration, the battery bank has the same voltage as a single battery, but an Ah rating equal to the sum of the individual batteries. See below.

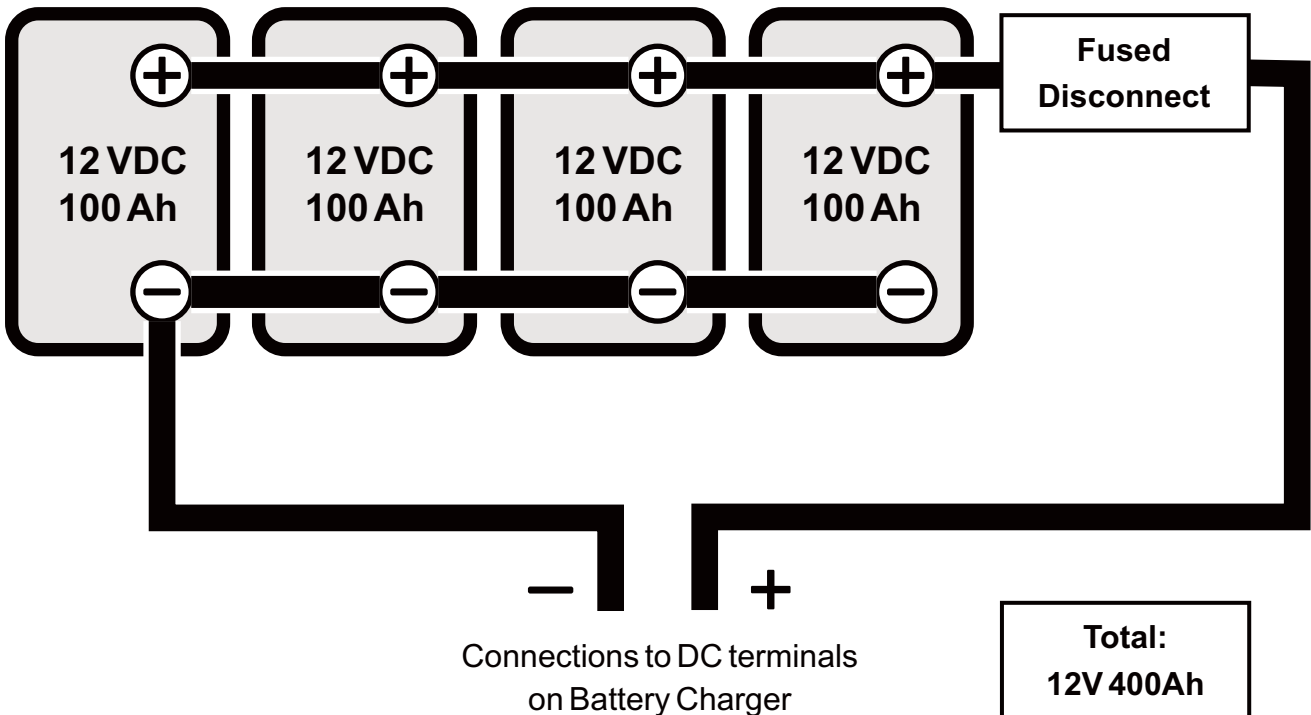

Battery Series Connection

When batteries are connected with the positive terminal of one battery to the negative terminal of the next battery, they are connected in series. In a series configuration, the battery bank has the same Ah rating of a single battery, but an overall voltage equal to the sum of the individual batteries. See below.

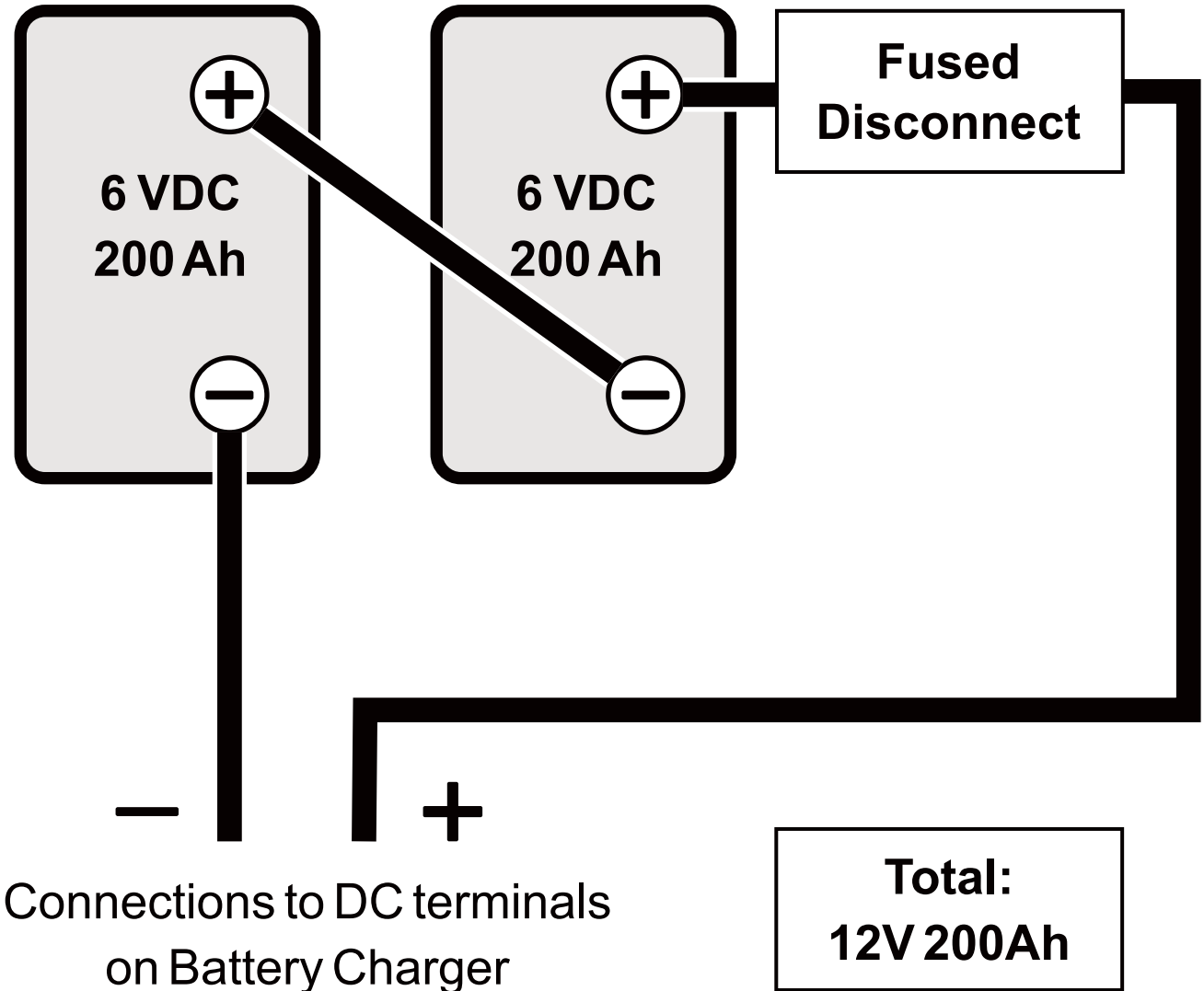

Battery Series-Parallel Connections

As the name series-parallel implies, both the series and parallel configurations are used in combination. The result is an increase in both the voltage and the capacity of the total battery bank. This is common with all battery-inverter system voltages. The smaller, lower voltage batteries are first connected in series to obtain the necessary voltage, and then these "batteries connected in series" sets are connected in parallel to increase the battery bank capacity. See below.

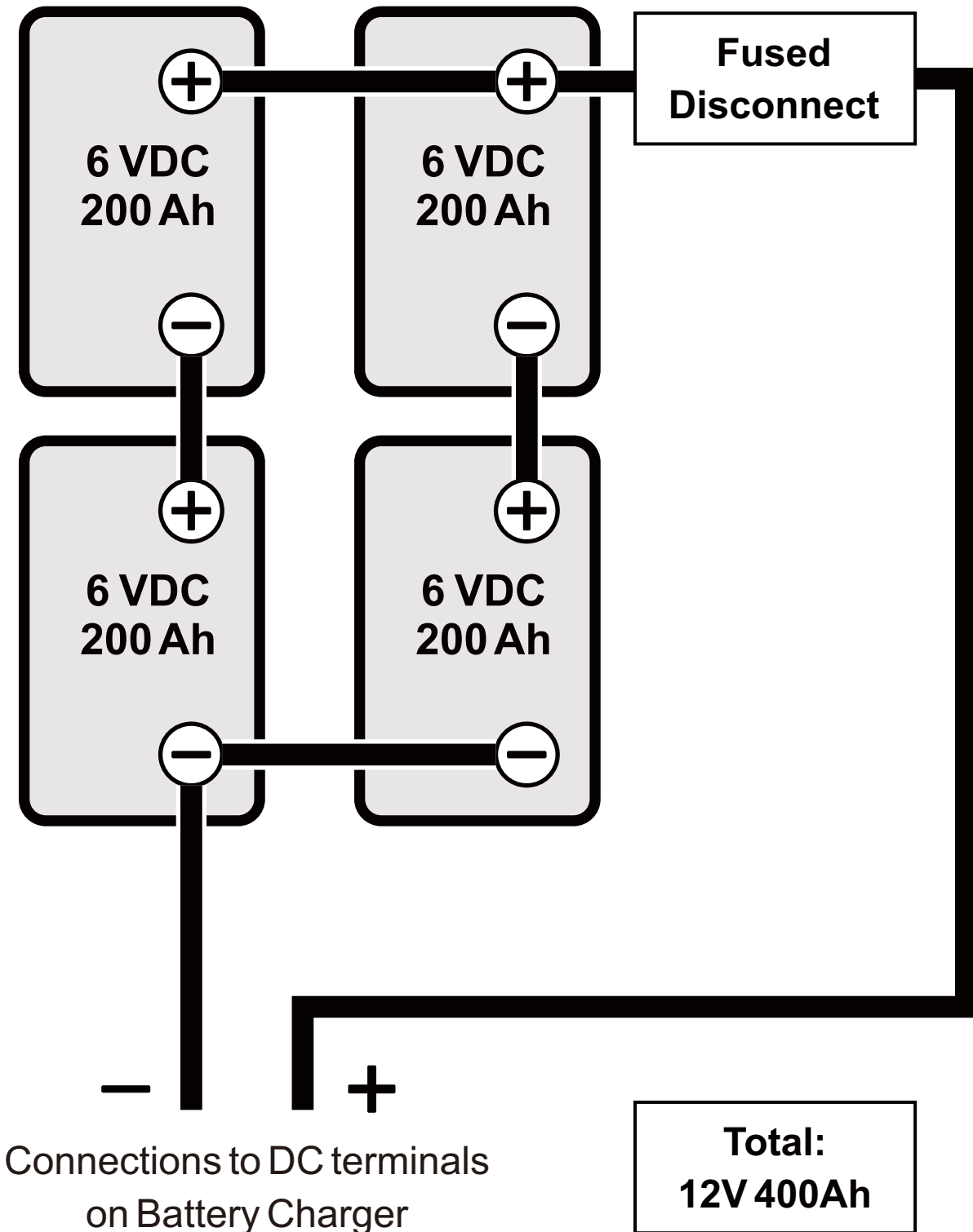

2.4 AC Input Connection

Use provided AC cable. Connect to a breaker minimum of 15A for BC112L. Connect to a breaker minimum of 25A for BC212L.

2.5 Parallel Connection

To get more charge current, Multiple Battery Chargers can be connected in parallel configuration. Up to five chargers may be connected in parallel .

3. Troubleshooting

Table 1 — 3: Troubleshooting list

Symptom	Probable cause	Items to examine or correct
NO LIGHTS	No battery power	Battery disconnected, over discharged, or connected in reverse, no display polarity.
	Power switch is not on	Turn on Power Switch.
AC power present at distribution panel	AC input is missing	Check AC input connections.
	Breaker has popped	Reset the input protector.
Green, yellow and red LED blinking 0.5s together	Mode select fault	Battery mode setting error.
Red LED blinking 0.5s other LEDs off	Fan fault	Check the fan in charger
Red LED Blinking 2s	The charger is operating over temperature	On the heat sink of DC-DC part should be operate below 105°C

If any other situations occur that are not listed above, call service technician immediately.

4. Specifications

4.1 Input				
Input Voltage	BC112L		BC212L	
	96-145Vac full performance 70-96Vac automatically derates to 50% of current Settings.			
Frequency	40Hz to 70Hz			
Nominal Input Current at Rated Output	<9Aac		<18Aac	
Voltage Measurement Accuracy	±8Vac			
Frequency Measurement Accuracy	±1Hz			
4.2 Output				
Nominal Voltage	BC112L		BC212L	
	12V	24V	12V	24V
Output Current	75A	37.5A	150A	75A
Rated Output Current	Manual adjustable			
Current Accuracy	± 6% of full rated output current @25°C, for target currents across the range from 10% rated output (for absorption exit criteria accuracy) to the current limit set point.			
Load Regulation	1.5%			
Selectable Battery Type	NMC, LiFePo4, Gel & AGM, Open Lead Acid,			
Parallel Outputs	Maximum of five AC converter units connected in parallel			
Efficiency	80%			
4.3 Protection				
Input Over Voltage	Unit must be safe for input voltage up to 150VacRMS (and up to 215Vpeak). Above this level the unit may be damaged.			
Input Under-voltage	Unit must not be damaged for all input voltages from 0-300Vac. Shutdown or input current limit or other means may be applied when input voltage is out of normal operating range.			
Output over voltage	Unit will shut down if charging voltage is above specified value by 1.0Vdc for more than 2 sec.; unit will restart when voltage returns to target range for more than 2 sec.			
Charger over temperature protection	The internal temperatures of the charger will be measured by NTC. Based on these measurements, unit will shut down if the temperature exceeds 105°C. Unit will restart when environment temperature cools to 95 °C.			

Optional BTS (Battery Temperature Sensor)	<p>The battery temperature sensor allows the charge controller to continuously adjust charge voltage / charge current based on actual battery temperature.</p> <p>When the battery temperature is over 40 °C, unit will reduce the charging voltage to Float voltage, also it will reduce the Max charging current by 10% with every two degree of temperature rise.</p> <p>When the battery temperature is over 50 °C,unit will shut down.</p>	
4.4 Environmental		
Operation temperature	<p>Nominal ambient temperature: 25°C Operating Ambient Temperature range: -10°C to 40°C (On the heat sink of DC-DC part, if the temperature is over 90 °C, the Charger Current will be derate to 50% ; if the temperature is over 105 °C, the Unit will be shut down.)</p>	
Relative humidity	5~95% without condensation	
Noise	Unit requirements: below 50dB (A) measured at 1 m distance with fan full working.	
Storage Conditions Temperature	-20°C to +80°C	
Cooling	Smart fan control	
Safety	UL458, CSA22.2#107.1	
4.5 Mechanical		
Unit Dimension (D x W x H) mm	261.4*160*70(mm)	315.5*183*85(mm)
Shipping Dimension (D x W x H) mm	346*191*122(mm)	425*255*167(mm)
Unit Weight	2.5Kg	3.5Kg
Gross Weight	2.77Kg	3.92Kg